ABSTRACT

The multilevel inverter has gained much attention in recent years due to its advantages in high power with low harmonics applications. The general function of the multilevel inverter is to synthesize a desired high voltage from several levels of dc voltages that can be batteries, fuel cells, etc. Cascaded H-bridge (CHB) multilevel inverter is one of the popular converter topologies used in high-power medium-voltage (MV) drives. The H-bridge cells are normally connected in cascade on their ac side to achieve medium-voltage operation and low harmonic distortion. Multilevel carrier based PWM method is used to produce a five level phase voltage. The inverter can be used in hybrid electric vehicles (HEV) and electric vehicles (EV). The cascaded H-bridge inverter using eight switches and two separate DC sources is modeled. A simulation model based on MATLAB/SIMULINK is developed.

KEYWORDS— - Multilevel Inverter (MLI), Sinusoidal Pulse Width Modulation (SPWM), Cascaded H-Bridge (CHB).

INTRODUCTION (BAYESIAN TECHNIQUE)

Numerous industrial applications have begun to require higher power apparatus in recent years. Some medium voltage motor drives and utility applications require medium voltage and megawatt power level. For a medium voltage grid, it is troublesome to connect only one power semiconductor switch directly. As a result, a multilevel power converter structure has been introduced as an alternative in high power and medium voltage situations. A multilevel converter not only achieves high power ratings, but also enables the use of renewable energy sources. Renewable energy sources such as photovoltaic, wind, and fuel cells can be easily interfaced to a multilevel converter system for a high power application.

The term multilevel began with the three-level converter. Subsequently, several multilevel converter topologies have been developed [2]. However, the elementary concept of a multilevel converter to achieve higher power is to use a series of power semiconductor switches with several lower voltage dc sources to perform the power conversion by synthesizing a staircase voltage waveform. Capacitors, batteries, and renewable energy voltage sources can be used as the multiple dc voltage sources. The commutation of the power switches aggregate these multiple dc sources in order to achieve high voltage at the output; however, the rated voltage of the power semiconductor switches depends only upon the rating of the dc voltage sources to which they are connected.

FIVE-LEVEL CASCADED MULTILEVEL INVERTER

This paper mainly deals with five-level cascaded multilevel inverter. The output is a five-level phase voltage. As the name suggests, the cascaded H-bridge multilevel inverter uses multiple units of H-bridge power cells connected in a series chain to produce high ac voltages. A typical configuration of a five-level CHB inverter is shown in Figure. 1 where each phase leg consists of two H-bridge cells powered by two isolated dc supplies of equal voltage E [1].

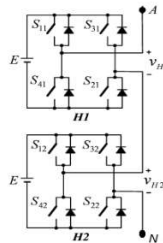

Figure.1 Five level cascaded H-bridge inverter

The dc supplies are normally obtained by multi pulse diode rectifiers. The CHB inverter in Fig3.1 can produce a phase voltage with five voltage levels. When switches S11, S21, S12, and S22 conduct, the output voltage of the H-bridge cells H1 and H2 is $V_{H1} = V_{H2} = E$, and the resultant inverter phase voltage is $V_{AN} = V_{H1} + V_{H2} = 2E$, which is the voltage at the inverter terminal A with respect to the inverter neutral N. Similarly, with S31, S41, S32, and S42 switched on, $V_{AN} = -2E$. The other three voltage levels are E, 0, and -E, which correspond to various switching states summarized in Table.1. It is worth noting that the inverter phase voltage V_{AN} may not necessarily equal the load phase voltage V_{AO} , which is the voltage at node A with respect to the load neutral O [7]. It can be observed from Table .1 that some voltage levels can be obtained by more than one switching state.

Table. 1 Voltage level and switching state of the five-level CHB inverter

Output Voltage v_{AN}	Switching State				v_{H1}	v_{H2}
	S_{11}	S_{31}	S_{12}	S_{32}		
2E	1	0	1	0	E	E
E	1	0	1	1	E	0
	1	0	0	0	E	0
	1	1	1	0	0	E
	0	0	1	0	0	E
0	0	0	0	0	0	0
	0	0	1	1	0	0
	1	1	0	0	0	0
	1	1	1	1	0	0
	1	0	0	1	E	-E
	0	1	1	0	-E	E
-E	0	1	1	1	-E	0
	0	1	0	0	-E	0
	1	1	0	1	0	-E
	0	0	0	1	0	-E
-2E	0	1	0	1	-E	-E

The voltage level E, for instance, can be produced by four sets of different (redundant) switching states. The switching state redundancy is a common phenomenon in multilevel converters. It provides a great flexibility for switching pattern design, especially for space vector modulation schemes. The number of voltage levels in a CHB inverter can be found from $m = (2H + 1)$, where H is the number of H-bridge cells per phase leg. The voltage level m is always an odd number for the CHB inverter while in other multilevel topologies such as diode-clamped inverters, it can be either an even or odd number.

CLASSIFICATION OF MODULATION STRATEGIES

The modulation methods used in multilevel converters can be classified according to switching frequency as shown in Figure.2 [1].

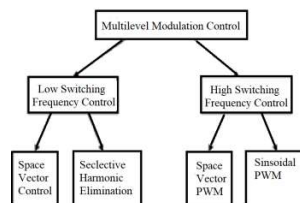

Figure 2: Classification of multilevel modulation methods

Methods that work with high switching frequencies have many commutations for the power semiconductors in one cycle of the fundamental output voltage. The popular methods for high switching frequency methods are classic carrier based sinusoidal PWM (SPWM) and space vector PWM. The popular methods for low switching frequency methods are space vector modulation (SVM) method and selective harmonic elimination method. A very popular method with high switching frequency in industrial applications is the classic carrier-based sinusoidal PWM (SPWM) that uses the phase-shifting technique to increase the effective switching frequency. Therefore, the harmonics in the load voltage can be reduced [5]. Another interesting method is the SVM strategy, which has been used in three-level converters. Methods that work with low switching frequencies generally perform one or two commutations of the power semiconductors during one cycle of the output voltages to generate a staircase waveform. Representatives of this family are the multilevel selective harmonic elimination based on elimination theory and the space-vector control (SVC).

CARRIER BASED PWM TECHNIQUES

In carrier based PWM schemes the for m level, (m-1) carrier waves are used. The carrier base PWM schemes are classified into two, they are, (i) Phase shifted multi carrier modulation,(ii) Level shifted multi carrier modulation The level shifted multi carrier modulation schemes are classified into three, they are,(i) In phase disposition method (ii)Alternative phase opposite disposition method and (iii) Phase opposite disposition method [2] [5].

Multilevel SPWM

Several multicarrier techniques have been developed to reduce the distortion in multilevel inverters, based on the classical SPWM with triangular carriers. Some methods use carrier disposition and others use phase shifting of multiple carrier signals

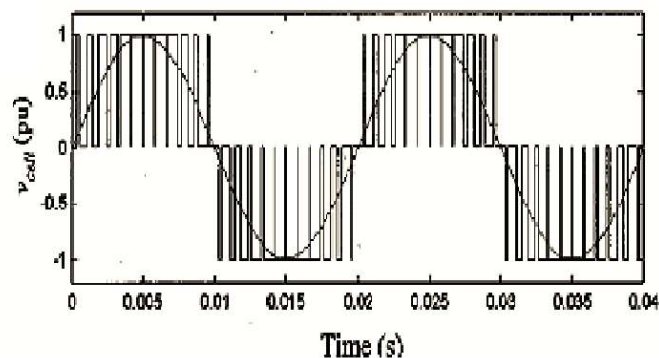

Figure.3 Output voltage and reference with SPWM.

Figure.3 shows the typical voltage generated by one cell for the inverter shown in Fig. 4 by comparing a sinusoidal reference with a triangular carrier signal. A number of N_c -cascaded cells in one phase with their carriers shifted by an angle $\theta_c = 360^\circ/N_c$ and using the same control voltage produce a load voltage with the smallest distortion. Another advantageous feature of multilevel SPWM is that the effective switching frequency of the load voltage is times the switching frequency of each cell, as determined by its carrier signal. This property allows a reduction in the switching frequency of each cell, thus reducing the switching losses

SIMULATION RESULTS

Figure. 4 shows the Matlab/Simulink Model of single phase five level Cascaded H-Bridge multilevel Inverter

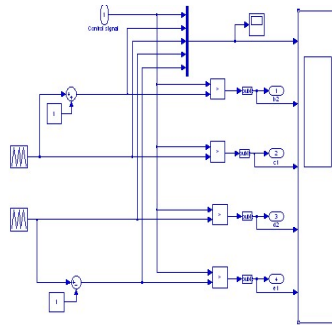

Figure.5 Simulink model of pulse width modulation generation.

The three sinusoidal signals are given to the control signal of input port of PWM generation model. Figure.5 shows the SIMULINK model of pulse width modulation generation.

The reference wave (sine) and carrier waves (triangular) for a five level CMI with SPWM is shown in figure 6.. One modulating wave V_r and four carrier waves : $+V_c, -V_c, +2V_c, -2V_c$

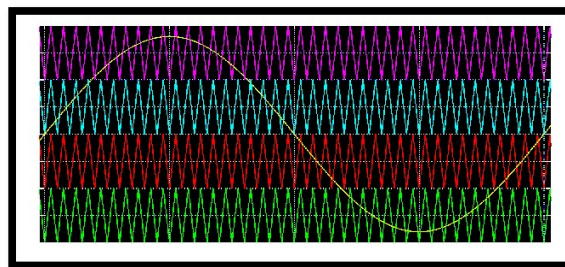

Figure.6 Generation of pulses for a five-level CMI

Figure.7 Shows Generation of pulses with Phase shift of $360/m_c = 90$ degrees.the number of voltage levels $m=5$ and Number of carriers: $m_c=m-1=4$.

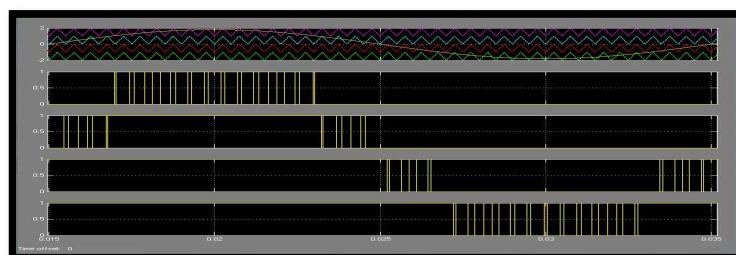

Figure.7 Carrier based PWM

Figure.8 shows the Output voltage for five-level cascaded multilevel inverter

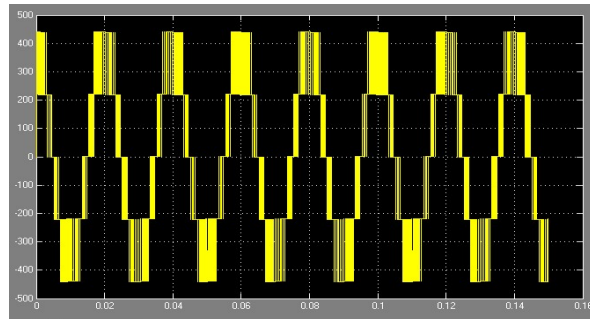

Figure.8 Output voltage waveform for five-level cascaded multilevel inverter

CONCLUSION

Multilevel inverter is a very promising technology in the power industry. This paper proposed a cascaded H-bridge multilevel inverter using eight switches and two separate DC sources to generate five-level phase voltage with minimum devices. The circuit configuration is simple and easy to control. The operational principle and key waveforms are illustrated and analyzed. The sinusoidal PWM scheme is used for modulation control. A cascaded multilevel inverter with PWM control method is designed and implemented in Simulink co-simulation platform.

REFERENCES

- [1] L. M. Tolbert, F. Z. Peng, T. G. Habetler, "Multilevel converters for large electric drives," IEEE Transactions on Industry Applications.
- [2] J. S. Lai and F. Z. Peng, "Multilevel converters – A new breed of power converters," IEEE Transactions on Industry Applications.
- [3] J. Rodríguez, J. Lai, and F. Peng, "Multilevel inverters: a survey of topologies, controls and applications," IEEE Transactions on Industry Applications.
- [4] S. Khomfoi, L. M. Tolbert, "Multilevel power converters," Power Electronics Handbook, 2nd Edition Elsevier.
- [5] J. Liao, K. Corzine, M. Ferdowsi, "A new control method for single-DC-source cascaded H-Bridge multilevel converters using phase-shift modulation," IEEE Applied Power Electronics Conference and Exposition.
- [6] Y. Zhang, Z. Zhao, H. Bai, L. Yuan, H. Zhang, "PSIM and SIMULINK co-simulation for three-level adjustable speed drive systems" IEEE Power Electronics and Motion Control Conference.
- [7] J. N. Chiasson, B. Özpıneci, Z. Du, and L. M. Tolbert, "A five-level three-phase hybrid cascade multilevel inverter using a single DC source for a PM synchronous motor drive," IEEE Applied Power Electronics Conference.
- [8] Z. Du, B. Özpıneci, L. M. Tolbert, J. N. Chiasson, "Inductorless DC-AC cascaded H-Bridge multilevel boost inverter for electric/hybrid electric vehicle applications," IEEE Industry Applications Society Annual Meeting.
- [9] J. N. Chiasson, B. Özpıneci, Z. Du, and L. M. Tolbert, "Conditions for capacitor voltage regulation in a five-level cascade multilevel inverter: application to voltage-boost in a PM drive," IEEE International Electric Machines and Drives Conference.
- [10] Z. Du, L. M. Tolbert, J. N. Chiasson, "A cascade multilevel inverter using a single DC source," IEEE Applied Power Electronics Conference.